

PLAN VIEW

FOR NEW MANHOLE CONSTRUCTION, CONTRACTOR TO MINIMIZE PIPE PROTRUSION (L)

REFER TO MANHOLE SIZING CHART TO ENSURE PROJECT SPECIFIC DESIGN FEASIBILITY

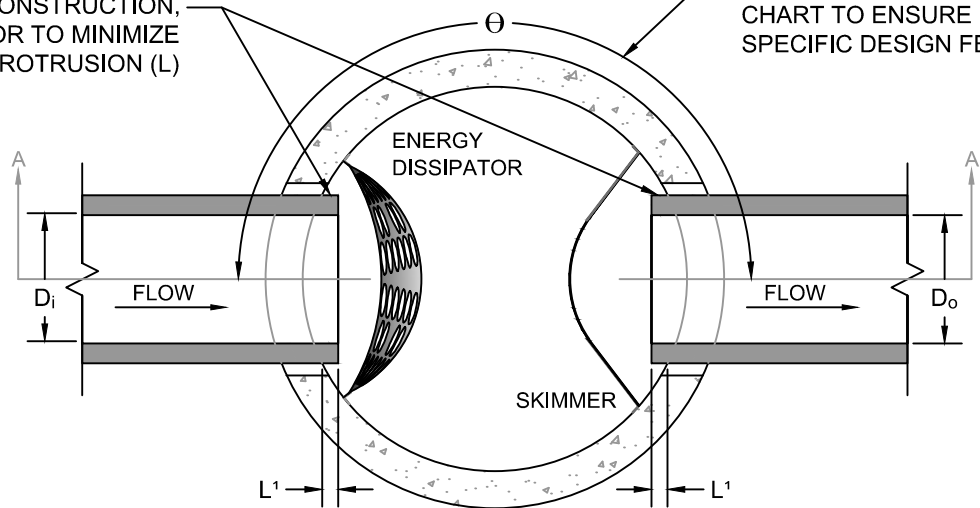

NOTE 1: STOCK COMPONENTS ARE DESIGNED TO ACCOMMODATE A 6" CONCRETE PIPE PROTRUSION (L, MEASURED AT SIDE OF PIPE). FOR CUSTOM DESIGNS, AND/OR PROJECT SPECIFIC DETAILS, CONTACT MOMENTUM.

Distributed by:



www.quicksupplydm.com
(515)289-1271

CROSS SECTION AA

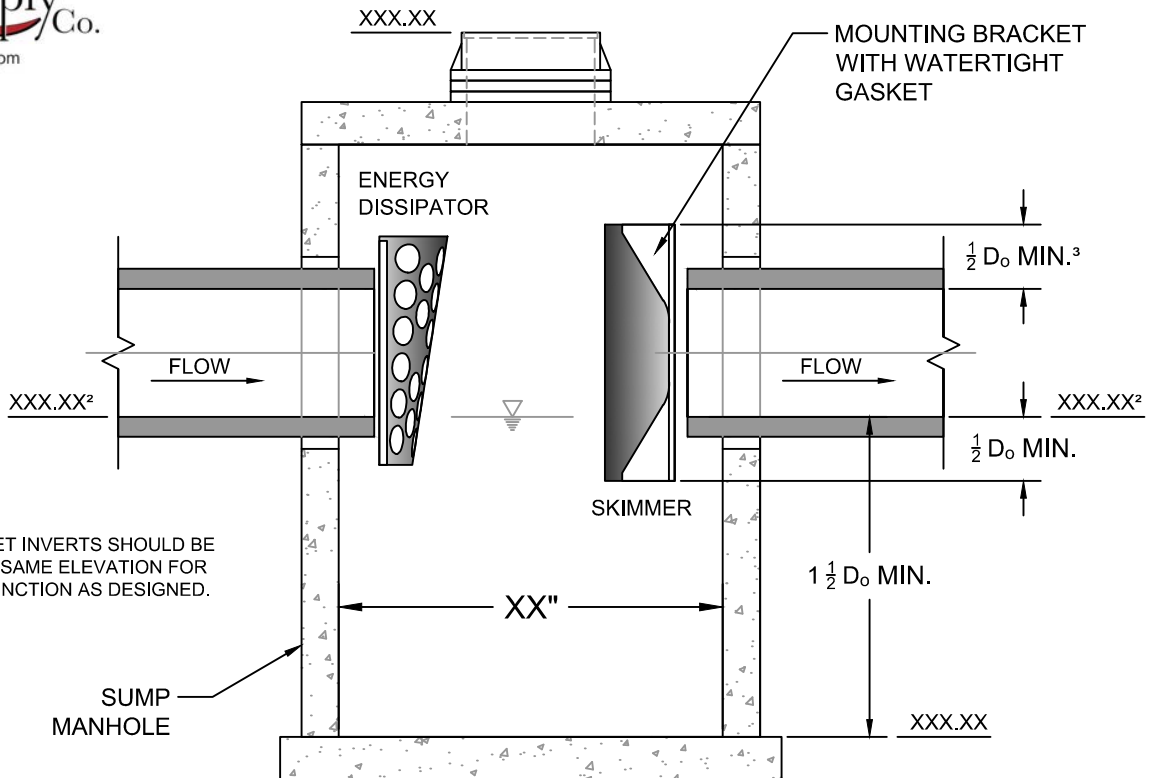

NOTE 2: INLET AND OUTLET INVERTS SHOULD BE AT APPROXIMATELY THE SAME ELEVATION FOR THE PRESERVER™ TO FUNCTION AS DESIGNED.

NOTE 3: STOCK SKIMMERS HAVE A FREEBOARD DEPTH OF $\frac{1}{2} D_o$. FOR GREATER FREEBOARD DEPTHS, DESIGNERS CAN UPSIZE THE SKIMMER, OR USE A CUSTOMIZED SKIMMER. FOR CUSTOM DESIGNS, AND/OR PROJECT SPECIFIC DETAILS, CONTACT MOMENTUM.

Not to Scale Distributed by: Bowman Construction Supply, 10801 E. 54th Avenue, Denver, CO 80239; Phone: (303) 696-8960



Momentum
ENVIRONMENTAL

SIMPLE • EFFECTIVE • AFFORDABLE • STORMWATER SOLUTIONS

877-773-0073 • www.MomentumEnv.com

THE PRESERVER™
STANDARD DETAIL

ENERGY DISSIPATOR
WITH SKIMMER

MADE IN THE USA
QUALITY MATERIALS
• 100% recycled HDPE
• Stainless steel brackets
• Stainless steel hardware

CONCEPTUAL PLAN DISCLAIMER:

THIS GENERIC DETAIL DOES NOT ENCOMPASS THE SIZING, FIT, AND APPLICABILITY OF THE PRESERVER FOR THIS SPECIFIC PROJECT. IT IS THE ULTIMATE RESPONSIBILITY OF THE DESIGN ENGINEER TO ASSURE THAT THE STORMWATER SYSTEM DESIGN IS IN FULL COMPLIANCE WITH ALL APPLICABLE LAWS AND REGULATIONS. MOMENTUM ENVIRONMENTAL LLC DOES NOT APPROVE PLANS, SIZING, OR SYSTEM DESIGNS. THE DESIGN ENGINEER IS RESPONSIBLE FOR ALL DESIGN DECISIONS.